

FPSLIC 1.

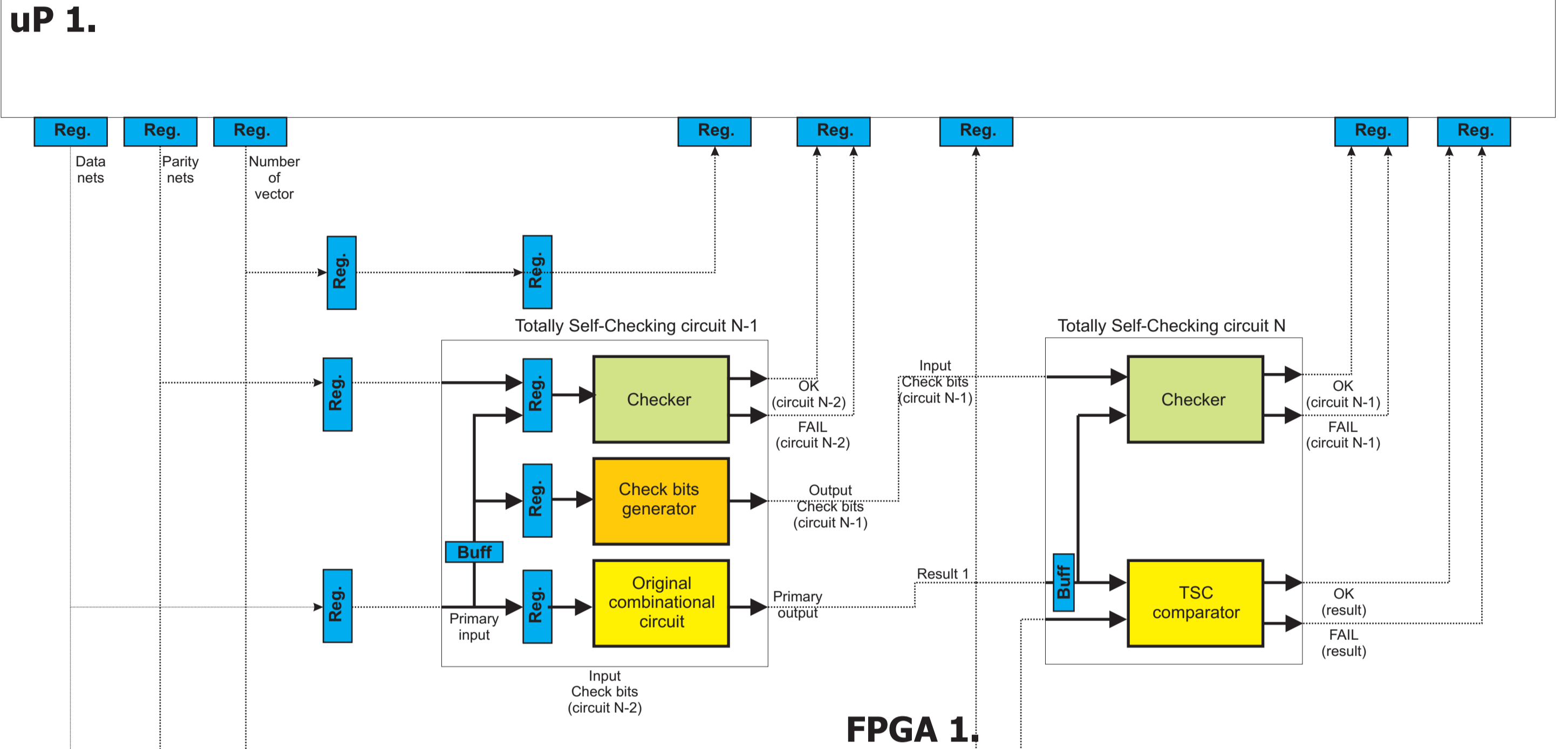

FPSLIC 2.

